

MAINTENANCE MANUAL

CBL-3L HOOK ASSEMBLY



*Charles B. Lewis Co.
P.O. Box 507
Banks, OR 97106 USA*

*Phone: 503-694-5670
Email: Info@cblco.com*

MAINTENANCE MANUAL

Table of Contents

- 1 Overview 3**
- 2 Tools Required For Maintenance..... 3**
- 3 Exploded View Of Components..... 4**
- 4 Disassembly Sequence 5**
- 5 Component inspection 11**
- 6 Assembly Sequence 13**
- 7 Revision Sheet 20**

1 Overview

- 1.1 The CBL-3L hook assembly is used to lift 500 lb bales of pulp that are common in the international shipping industry. The CBL-3L hook assembly uses lubricants and compressed air or nitrogen and is often operated in a sea-air environment. This environment requires that the assembly be periodically disassembled, and the components inspected and replaced or re-lubricated and reassembled.
- 1.2 The CBL-3L is rated to lift 3,000 kg (6,615 lbs) with a 5:1 factor of safety.
- 1.3 It is proof load tested to 6,000 kg (13,230 lbs).
- 1.4 It is air activated with a maximum of 40psi air.
- 1.5 It is suspended from ½” Grade 8 alloy chain.
- 1.6 Each hook body casting is engraved with a Serial Number.
- 1.7 All components need to be maintained to insure proper and safe function.
- 1.8 Do not use any replacement parts that are not approved by the Charles B Lewis company.

2 Tools Required For Maintenance

- 2.1 The tools necessary to perform disassembly, inspection, lubrication, and re-assembly are listed below:
 - 2.1.1 1/2” allen wrench or hex bit & extension, at least 4.25” long
 - 2.1.2 1/4” hex bit or allen wrench
 - 2.1.3 Mayhew 25007 1/4” roll pin punch or 1/4” diameter drift punch
 - 2.1.4 1/2” deep well socket and ratchet
 - 2.1.5 7/8” deep well socket
 - 2.1.6 Round dental pick
 - 2.1.7 Torque wrench capable of 17 ft-lb of torque
 - 2.1.8 Brass hammer
 - 2.1.9 Air tool oil (such as Napa air tool lubricant 765-1400 or equivalent). MSDS to be provided to maintenance personnel.
 - 2.1.10 Marine grease (such as Sta-Lube water resistant marine grease SL3121 or equivalent). MSDS to be provided to maintenance personnel.
 - 2.1.11 An extra 20003 Piston or flat ended 0.625” diameter rod
 - 2.1.12 Rubber tipped air nozzle
 - 2.1.13 Phillips screwdriver with shank less than 0.25” diameter
 - 2.1.14

3 Exploded View Of Components

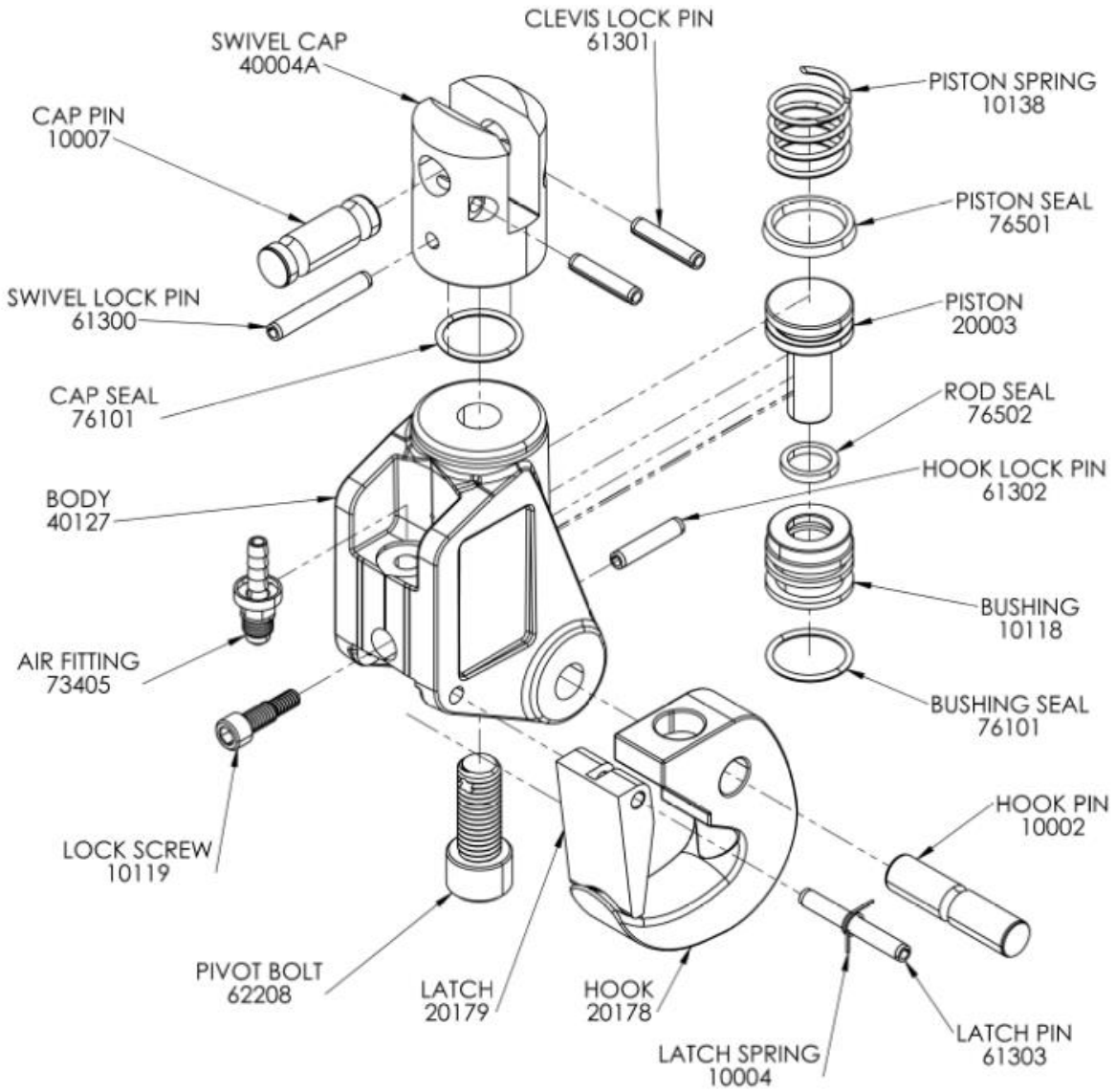

4 Disassembly Sequence

4.1 Disconnect the air hose from the hook assembly:

4.1.1 Confirm there is no pressure in the air hose leading to the hook assembly.

4.1.2 Loosen the hose clamp (if any) around the 73405 Air Fitting.

4.1.3 Pull the hose off the Air Fitting using an orbiting tugging motion.

4.2 Disconnect the CBL-3L Hook Assembly from the 5/8" steel chain from which it is suspended.

4.2.1 Use Mayhew 25007 1/4" roll pin punch or 1/4" diameter drift punch to drive out the two 61301 Clevis Lock Pins.

4.2.2 Slide out the 10007 Cap Pin.

4.3 Remove the 20178 Hook from the Hook Assembly.

4.3.1 Use a Mayhew 25007 1/4" roll pin punch or 1/4" diameter drift punch to drive out the 61302 Hook Lock Pin.



4.3.2

4.3.3 Slide out the 10002 Hook Pin.



4.3.4

4.4 Remove the 20179 Latch from the Hook Assembly.

4.4.1 Use a Mayhew 25007 1/4" roll pin punch or 1/4" diameter drift punch to drive out the 61303 Latch Pin, and when it is nearing half-way out, hold on to the 10004 Latch Spring to keep it from springing away.



4.4.2

4.5 Remove the 20003 Piston and 10118 Bushing assembly from the 40127 Body.

4.5.1 Use a 1/4" allen wrench or hex bit to remove the 10119 Lock Screw.



4.5.2

4.5.3 Thread a 1/4-20 fastener into the tip of the piston and pull on it to pull the Piston and Bushing assembly out of the bore in the Body.

4.6 Remove the 10138 Piston Spring from the bore in the Body.



4.7

4.8 Use a round dental pick to remove the 76501 Piston Seal from the Piston and Bushing assembly. Be careful to not scratch the Piston nor tear the Piston Seal.

4.9 Remove the 10118 Bushing assembly from the Piston and Bushing assembly by sliding it off the Piston.



4.10

4.11 Use a round dental pick to remove the 76101 Bushing Seal from the Bushing. Be careful to not scratch the Bushing nor tear the Bushing Seal.



4.12

4.13 Use a round dental pick to remove the 76502 Rod Seal from the Bushing. Be careful to not scratch the Bushing nor tear the Rod Seal.



4.14

4.15 Remove the 62208 Pivot Bolt.

4.15.1 Use a 3/16" diameter drift punch to drive out the 61300 Swivel Lock Pin.

4.15.2 Use a 1/2" allen wrench (or hex bit & extension totalling at least 4.25" long) to remove the 62208 Pivot Bolt.

4.16 Use a round dental pick to remove the 76101 Cap Seal from its annular groove in the 40004A Swivel Cap. Be careful to not scratch the Swivel Cap nor tear the Cap Seal.



4.17

4.18 Use a 7/16" deep well socket to remove the Air Fitting from the body.



4.19

5 Component inspection

- 5.1 Clean dirt, debris, and lubricants from all components.
- 5.2 Inspect all components for worn surfaces and cracks.
- 5.3 Clean and inspect all seals and O-rings while stretching them to ensure that no cuts or tear are present.
- 5.4 Using a digital caliper, measure the diameter of the tip of the 20003 Piston.
 - 5.4.1 If at any location it is less than 0.588", replace the piston.
 - 5.4.2 If the tip of the piston is bent or deformed more than 0.035" or 5 degrees, replace the piston. Visually inspect and measure the worst side of the tip of the Piston, as it is free to rotate in the assembly.

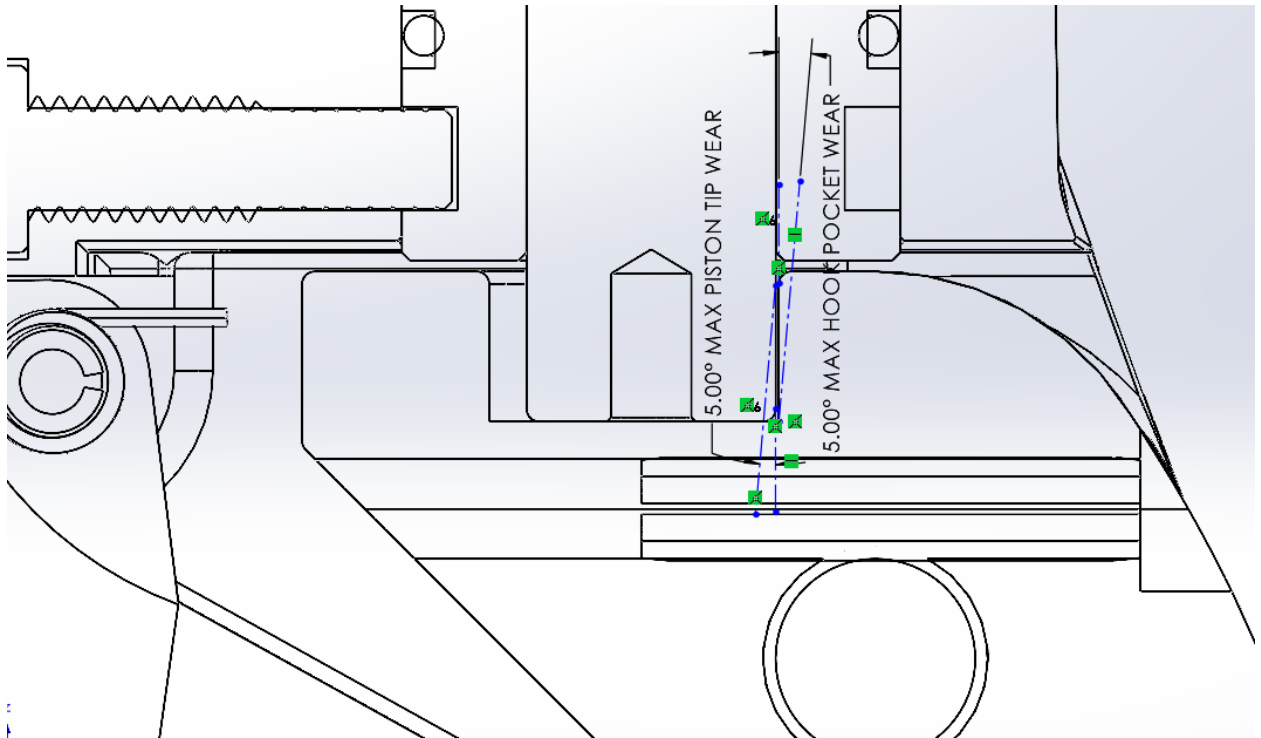

- 5.4.3
- 5.5 If the pocket in the 20178 Hook is deformed or worn more than 0.035" or 5 degrees, replace the Hook. The pocket is oval, not round. The pocket can be measured with a caliper to see if the shallow edge of the pocket is more than .035" larger than the deepest portion of the pocket, along the same direction.
 - 5.5.1 If the tip of the Piston and/or the pocket in the Hook are worn or deformed such that less than 75% of the "as new" contact area is currently contacting between them during lifting, then the Piston and/or Hook should be replaced.
- 5.6 If the wear of the Piston, Hook, or 10002 Hook Pin, or deformation of the Hook enables a .060"(1.5mm) pin to fit in the gap between the Hook and the 20179 Latch when lifting only 10 lbs, then one or all of the Piston, Hook, and/or Hook Pin components should be replaced.

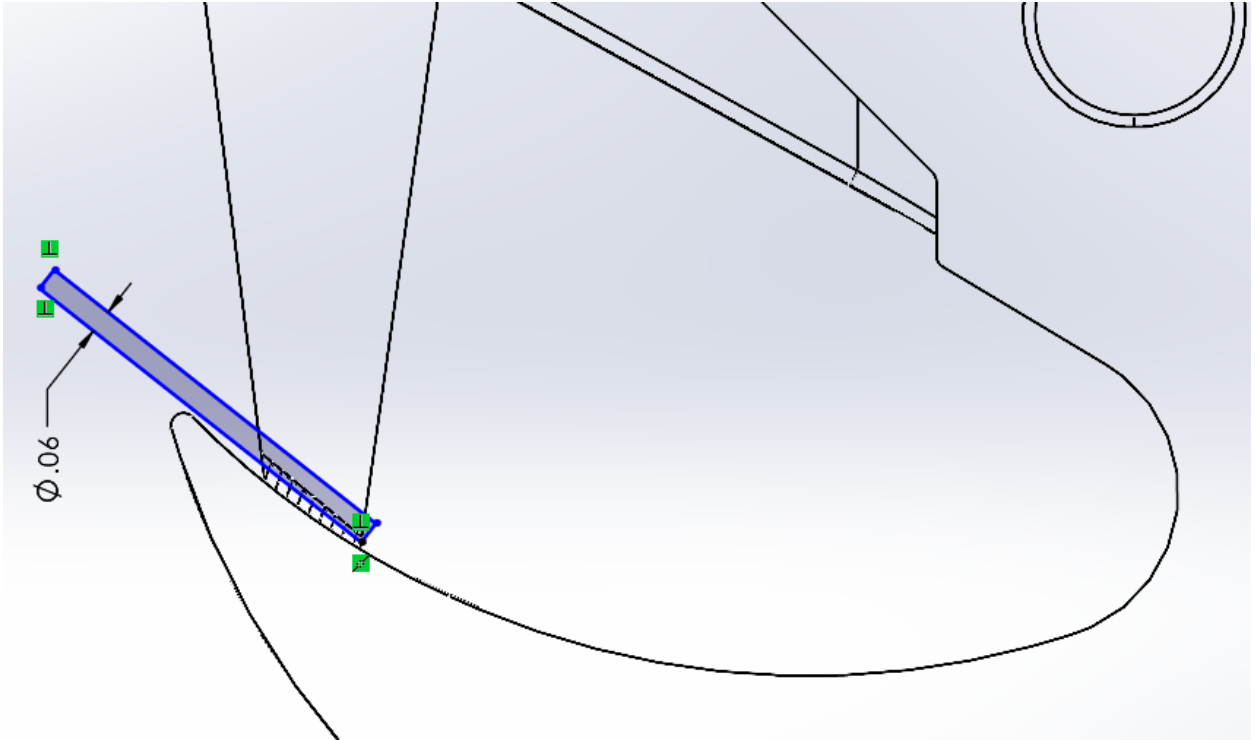

5.6.1

6 Assembly Sequence

6.1 Install the Air Fitting into the Body:

- 6.1.1 Confirm that the O-ring is not deformed or cut and is still on the air fitting.
- 6.1.2 Add 1 drop of Blue Loctite to the threads of the Air Fitting and hand-tighten into the Body.
- 6.1.3 Immediately use the 7/16" deep well socket and tighten the Air Fitting to 14 ft-lbs of torque.

6.2 Attach the Swivel Cap to the Body:

- 6.2.1 Lubricate the 76101 Cap Seal with Marine Grease and install it in the annular groove in the Swivel Cap.
- 6.2.2 Lubricate the flat face of the Swivel Cap with Marine Grease.
- 6.2.3 Lubricate under the head of the Pivot Bolt with Marine Grease.
- 6.2.4 Install the Pivot bolt through the Body into the Swivel Cap.
- 6.2.5 Torque the Pivot Bolt to about 17 ft-lb of torque but primarily align the hole in the Swivel Cap for the Swivel Lock Pin with the corresponding hole in the Pivot Bolt.
- 6.2.6 Twist the Swivel Cap with respect to the Body, by hand, to insure smooth operation.
- 6.2.7 Lubricate the Swivel Lock Pin with Marine Grease and use a Brass Hammer to install it thru the Swivel Cap and the Pivot Bolt until centered in the Swivel Cap. Use a Mayhew 25007 1/4" roll pin punch or 1/4" diameter drift punch to center it if necessary.
- 6.2.8 Again, twist the Swivel Cap with respect to the Body, by hand, to insure smooth operation.

6.3 Spray or wipe a light coat of Air Tool Oil into the Bore of the Body.

6.4 Install the Piston Spring.

6.5 Assemble the Bushing Sub-assembly:

- 6.5.1 Spray or wipe a light coat of Air Tool Oil onto the outside of the 10118 Bushing and especially in the (smaller) seal groove.
- 6.5.2 Stretch the 76101 Bushing Seal over the outside of the Bushing to install it in the seal groove. Be careful to not tear or slice the Bushing Seal on the exposed edges of the Bushing.

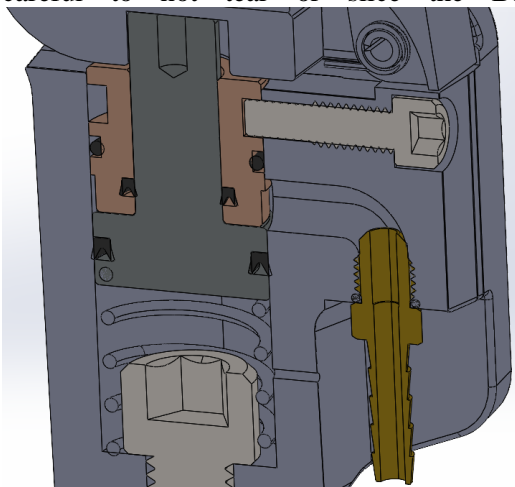

6.5.3 Spray or wipe a light coat of Air Tool Oil into the inside of the Bushing and especially in the seal groove.

6.5.4 Pinch the 76502 Rod Seal into a “heart” shape, if needed, as shown below...

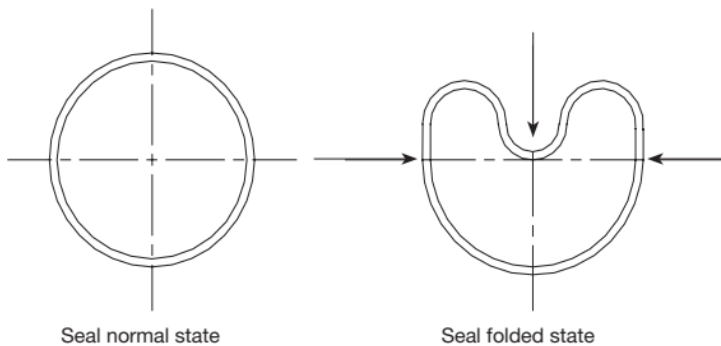

6.5.5

6.5.6 ...then install it in the inside of the Bushing. Be careful to not tear or slice the Rod Seal. **IMPORTANT:** Make sure the lip of the seal is pointing towards the closer end of the bushing, as shown in 7.5.2 above. This direction is not intuitive but is best for function.



6.5.7

6.6 Assemble the Piston Sub-assembly:

6.6.1 Spray or wipe a light coat of Air Tool Oil onto the outside of the 20003 Piston and especially in the seal groove.

6.6.2 Stretch the 76501 Piston Seal over the outside of the Bushing to install it in the seal groove. Be careful to not tear or slice the Piston Seal on the exposed edges of the Piston. **IMPORTANT:** Make sure the lip of the seal is pointing towards the larger diameter head end of the Piston. This direction is not intuitive but is best for function.

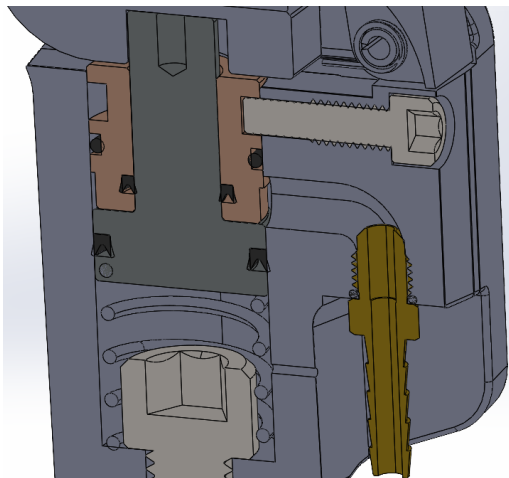

6.6.3

6.7 Assemble the Bushing & Piston Assembly:

6.7.1 Insert an unused Piston or 0.625" diameter rod into the Bushing Sub-Assembly from the top (large OD groove end) towards the bottom (small OD groove end). This deflects the lip of the Rod Seal in the correct direction.

6.7.2 Now push the Piston Sub-Assembly into the Bushing Sub-assembly from the opposite direction. This should enable the deflected lip of the Rod Seal to transfer from the unused Piston to the shaft of the Piston Sub-Assembly.



6.7.3

6.8 Install the Bushing and Piston Assembly into the Body:

6.8.1 Use the 7/8" Deep Well socket to push on the bushing and deflect the Spring and force the Bushing and Piston Assembly into the bore of the Body. Only push it far enough that the larger OD groove lines up with the threaded hole Body for the 119 Lock Screw.

6.8.2 Add 1 drop of blue Loctite to the threads of the Lock Screw and install it in the Body while the OD groove in the Bushing lines up with the threaded hole in the Body. Torque the Lock Screw to __ft-lb.

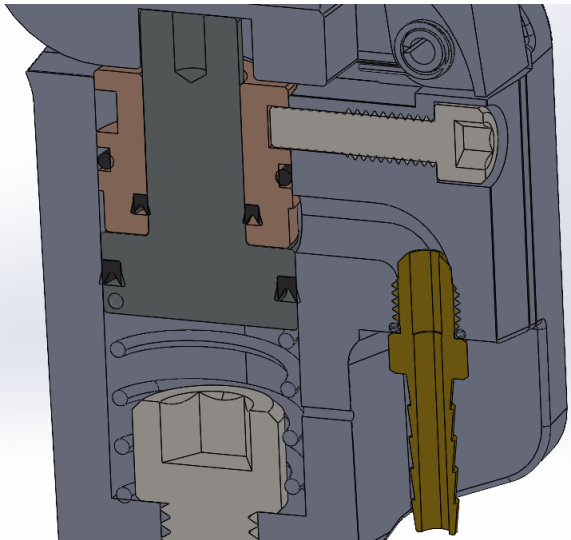

6.8.3

6.9 Check function of Piston Sub-Assembly:

6.9.1 Set air pressure regulator to 40psi on any shop air source

6.9.2 Press Rubber Tipped air nozzle against the open end of the Air Fitting and press the air nozzle trigger. The piston should retract into the Body about 0.4" and then return when the air pressure is removed. Both motions should be quick and smooth.



6.9.3

6.10 Install the 20179 Latch:

6.10.1 Insert a Phillips screwdriver with a shank less than 0.25" diameter thru one ear of the Body and through half of the Latch.

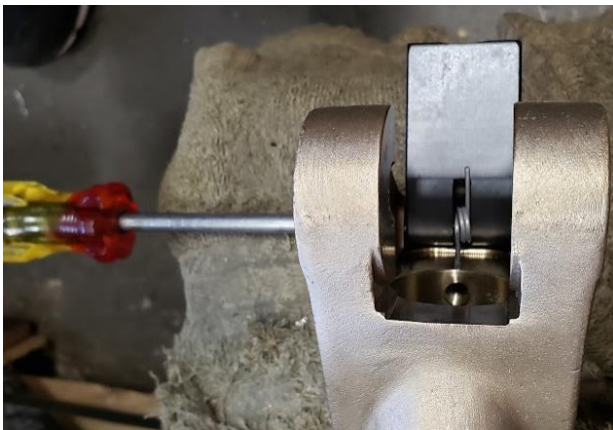

6.10.2

6.10.3 Hold the 10004 Latch Spring in the orientation shown below, then push the screwdriver the rest of the way through the Latch and Body.

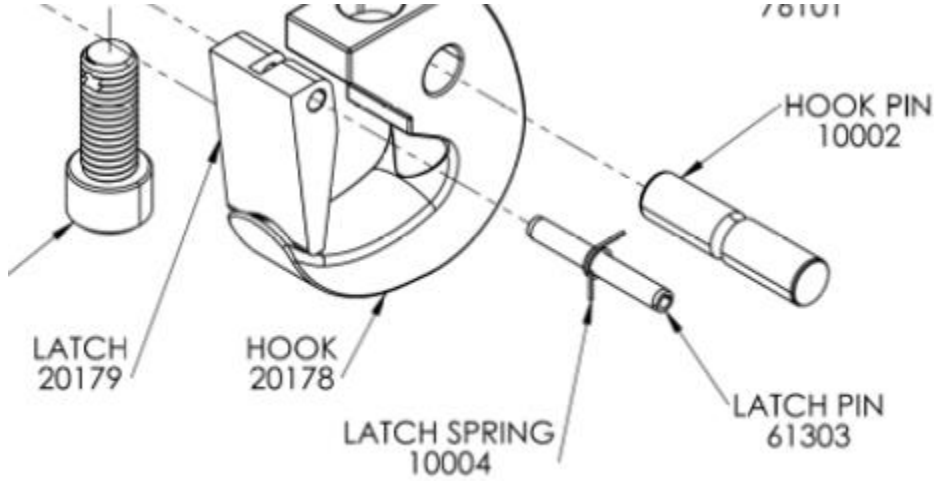

6.10.4

6.10.5 Lubricate the 60303 Latch Pin with Marine Grease.

6.10.6 Use a Brass Hammer and Mayhew 25007 1/4" roll pin punch or 1/4" diameter drift punch to install the Latch Pin from the opposite direction from which the Phillips screwdriver was inserted. The Latch Pin will push the Phillips Screwdriver out as it is installed. It will also transfer the Latch Spring from the Phillips Screwdriver to the Latch pin as it is installed.



6.10.7

6.10.8 Deflect the Latch at least 30 degrees by hand to confirm smooth rotating movement. The Latch Spring should return the Latch to its full extension (nearly vertical as shown below).



6.10.9

6.11 Install the 20178 Hook:

6.11.1 Lubricate the 61302 Hook Lock Pin with Marine Grease.

6.11.2 Position the 10002 Hook Pin in the Body such that the holes for the Hook Pin in both the Body and the Hook are aligned.



6.11.3

6.11.4 Slide the Hook Pin thru the Body and Hook until the Hook Pin is centered in the Body.

6.11.5 While keeping the Hook Pin centered, use a Brass Hammer and Mayhew 25007 1/4" roll pin punch or 1/4" diameter drift punch to install the Hook Lock Pin until flush with the machined counterbore in the Hook.



6.11.6

6.11.7 Rotate the Hook by hand until fully closed. The last part of this travel should slightly deflect the Latch and Piston and you should hear the Piston click into the pocket in the Hook.

6.11.8 Lightly pull open the Latch by hand while using the Rubber Tipped Air Nozzle to supply 40psi air to the open end of the Air Fitting. The piston should retract, and the Hook should rotate open. If too much force is exerted on the Latch by hand (or during Lifting), the Piston should not retract, and the Hook should not open. This is intended failsafe operation.

7 Revision Sheet

Release No.	Date	Revision Description
Rev. A	07/11/2022	Initial Release
Rev. B	02/15/2023	Added MSDS note for lubricants at 2.1.9 and 2.1.10 17/16 was 1/2 at 4.18 and 6.1.3.

Maintenance Manual Authorization

I have reviewed this Maintenance Manual of the Hook Assembly: CBL-3L.
This document has been completed in accordance with the requirements of Charles B. Lewis Company.

MANAGEMENT CERTIFICATION - Please check the appropriate statement.

_____ The document is approved.

_____ The document is approved, pending the changes noted below.

_____ The document is not approved.

Jim Hertel
NAME
President

2/16/2023
DATE

[Signature]